



Installation & maintenance instructions



Thank you for choosing the FiltraMag⁺, high performance magnetic filter. Before fitting please read this document which contains installation and maintenance guidance.

Range of application

The FiltraMag⁺ range has been specifically designed to be utilised in process fluid applications to remove contamination. The filters are easily integrated into process lines with ANSI Flanges

Pressure rating – Designed and tested to operate at 290 psi (20 bar) maximum line pressure.

Legal basis

This device corresponds to the machine guideline 206/42/EC.

General Information Safety

Intended use

The in-line filter is designed for installation into pressurised pipe lines working at up to 290 psi (20 bar). All pipeline connections are to be installed accurately and sealed to prevent the loss of pressure/product.

To ensure that the supplied magnets maintain their high level of performance, attention must be paid to the following conditions:

1. NO temperatures above the specific operating temperature
2. NO oscillating vibrations
3. NO impacts
4. Pay attention to the cleaning and maintenance of the system



General preventive measures

The rod is constructed with strong magnets. The handling of ferrous tools (e.g. with maintenance or cleaning) etc. can cause risk of injury for the personnel due to the magnetic attraction.

Special measures regarding the presence of ferrous items have to be considered when handling magnetic material.



Dangers during neglect of the safety notes

Using this equipment in a manner not intended

 can present safety hazards.

Safety notes for operation and maintenance

Maintenance work is to be executed only by qualified personnel.

With work on pneumatic, hydraulic, pressurised or electrical services the supply lines are to be isolated prior to any cleaning or maintenance actions. Prior to any maintenance work being carried out, the process, equipment used and personnel must be risk assessed and deemed suitable to conduct that task. All work is to be carried out in accordance with local and legislative regulations.

WARNING! This system incorporates strong permanent magnetic materials. Please pay attention to the safety notes in order to avoid personal injury or material-damage:

- Operators fitted with heart pace-makers shall not come within 1m of the equipment.
- Oppositional poles of magnets attract each other with high clamping forces.
- Do not use steel/iron tools or other ferrous parts in the flux field of the system.
- Data carriers, credit cards, computer drives etc can be erased by the influence of the magnetic field. Keep electronic and sensitive mechanical units (i. e. watches) away from the magnet.
- Please contact our service department before welding or drilling works on the unit.



Notes on residual risks

 Vent any trapped pressure from the process line prior to working on the unit.

Consequences with arbitrary change

With arbitrary change or repairs all warranties and assertions delivered by the manufacturer become void.



Only genuine OEM parts are to be used in any repair to maintain the manufacturer's warranty.

Prohibited operation

The unit must not be subjected to any high external loads or induced vibrations.

FiltraMag+ Components

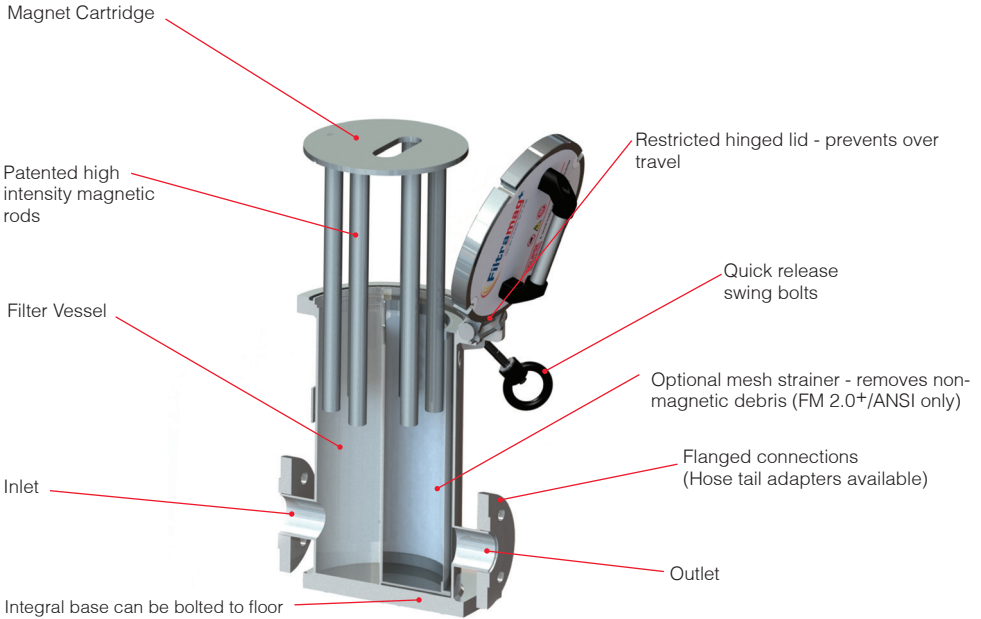

Technical data

Maximum Operating Temperature: 176°F (80°C)
Maximum Operating Pressure: 290 psi (20 bar)
Vessel Construction: Stainless Steel
Seal: Viton

Product number	ANSI Flange connection	Vessel Volume	*Total Weight	Contamination Capacity	Flow Rate gpm
FM1.5+/ANSI	1 1/2"	1.2 gallons (4.5 litres)	67 lbs (30.5 kg)	6.6 lbs (3 kg)	66
FM2.0+/ANSI	2"	3.2 gallons (12 litres)	119 lbs (54.0 kg)	13.2 lbs (6 kg)	132

*Weight includes Vessel and Magnet Cartridge

Gauss reading on tube surface
 Standard Rod (4,000) N35 NdFeB 4,000 Gauss
 High Intensity Rod (11,000) N45 NdFeB 11,000 Gauss

Noise data sheet
 Sound pressure level, measurement according to DIN 45635:
 Idling < 70 dB(A)
 Conveying < 70 dB(A)

Dimensions

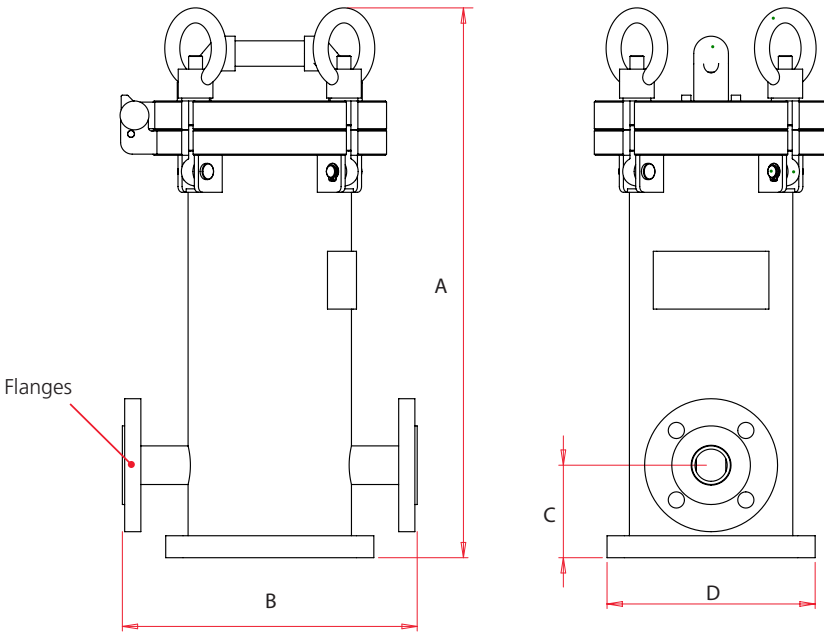

Product number	Connection	Dimensions inches			
		A	B	C	D
FM1.5 ⁺ /ANSI	1½"	15.5	10.0	3.9	7.1
FM2.0 ⁺ /ANSI	2"	17.4	13.0	3.9	9.8

Part Numbers (including Spares)

Part Number	Description
FM1.5 ⁺ /ANSI	FM1.5 ⁺ /ANSI unit with 4,000 magnet cartridge, cleaning tool & cleaning tray
FM2.0 ⁺ /ANSI	FM2.0 ⁺ /ANSI unit with 4,000 magnet cartridge, cleaning tool & cleaning tray
FM1.5 ⁺ /ANSI/11K	FM1.5 ⁺ /ANSI unit with 11,000 magnet cartridge, cleaning tool & cleaning tray
FM2.0 ⁺ /ANSI/11K	FM2.0 ⁺ /ANSI unit with 11,000 magnet cartridge, cleaning tool & cleaning tray
FM1.5 ⁺ /MC	4,000 magnet cartridge for FM1.5 ⁺ /ANSI units
FM2.0 ⁺ /MC	4,000 magnet cartridge for FM2.0 ⁺ /ANSI units
FM1.5 ⁺ /MC11K	11,000 magnet cartridge for FM1.5 ⁺ /ANSI units
FM2.0 ⁺ /MC11K	11,000 magnet cartridge for FM2.0 ⁺ /ANSI units
FM2.0 ⁺ /MB0.5	Optional 0.5mm mesh basket for FM2.0 ⁺ /ANSI units
FM2.0 ⁺ /MB1.0	Optional 1.0mm mesh basket for FM2.0 ⁺ /ANSI units
FM1.5 ⁺ /VS	Spare viton seal for FM1.5 ⁺ /ANSI units
FM2.0 ⁺ /VS	Spare viton seal for FM2.0 ⁺ /ANSI units

Design and method of operation

Method of operation

The magnetic filter is designed with dual flow technology with an internal baffle and multi-core magnet cartridges which maximise contamination collection.

Optional spare magnet cartridges are available to enable production continuity when the magnet cartridge is removed for cleaning.

Optional mesh baskets are available for the FM2.0⁺/ANSI version for collection of non-magnetic contamination.

The inlet and outlet ports are in-line for ease of integration.

Installation / Operation

Mechanical installation

For optimum performance the unit is to be installed as follows:

- Before installation ensure that all supplies are isolated.
- Install the vessel in-line with the fluid process.
- Inlet flange is on the opposite side of lid hinges
- Secure the vessel with the inlet / outlet flanges including suitable gasket
- Ensure seal is clean and located correctly into the groove.
- Fit optional mesh basket if applicable (FM2.0⁺/ANSI only)
- Install the magnet cartridge with the "IN" marking towards the inlet side of the vessel
- Close lid and secure with swing bolts
- Turn fluid on

Connections

- No external power sources required for this product

Setting of the operating parameter

- No customer adjustment available to this unit

Dismantling & Cleaning

Cleaning

Please refer to the cleaning operations below.

- Isolate the filter from the system flow
- Unscrew the swing bolts on the lid (**Fig 1**)
- Open the lid using the lid handle (**Fig 2**)
- Lift the magnet cartridge assembly out of the body and move it away to a cleaning station. (**Fig 3**)
- Stand the magnet cartridge on the “cleaning tray” provided.
- Using the “cleaning tool” provided, scrape the bulk of the ferrous contamination off the magnet core – it is not essential to remove all of the collected contamination (**Fig 4**)
- Remove and clean the mesh basket (if applicable) (**Fig 5**)
- Refit the mesh basket into the vessel.
- Refit magnet cartridge
- Clean seal and re-fit
- Tighten swing bolts
- Switch on system flow.

Do not use corrosive substances to clean the equipment

Maintenance

General notes

- Keep the system clean, especially the magnetic rods
- Regularly check of the seal for defects
- Regularly check the tube surface for wear
- Do not clean with aggressive cleaner!
- Do not clean the magnet rods with water!

i **Moisture on the bar magnets leads to corrosion and possible damage to the system.**

It is strongly recommended that regular inspections are carried out to check for moisture and that appropriate action is taken to ensure the bar magnets are dried thoroughly.

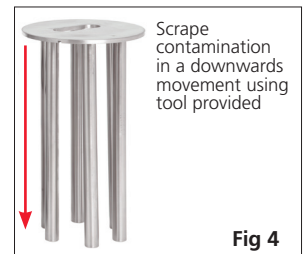
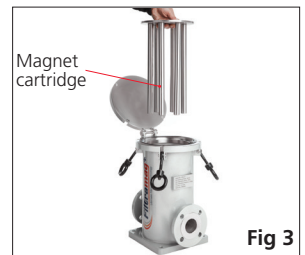
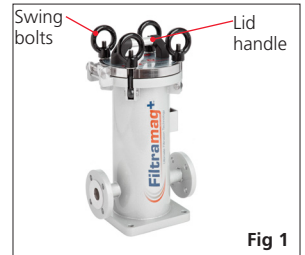

Shipping, preservation, waste disposal, transport, storage

Shipping, preservation, waste disposal

 1. Select a suitable packing depending upon type and range of the transmission (export, sea air freight, truck national, internationally). The packing must be selected in such a way that under normal transport prerequisites no damage to the commodity can occur.

 2. National transmissions are packed exclusively truck-transportable depending upon scope, weight and condition of the commodity in cardboard, cardboard pallets etc.. When filling and protection material in the packing strengthened cardboard, cardboard, air cushion foil and shred paper used.

On the packing outside warning labels are additional to attach, e.g.: 'Caution! High energy magnet. Do not throw'. The packing is locked with tape and with weights starting from 110 lbs additionally with safety tape.

 3. International truck transmissions are packed accordingly to point 2, larger and heavier transmissions depending upon protection neediness also export-fairly in wooden boxes. (Attention should be given to corrosion protection). Easily corrosive sections are to be packed before the packing in oiled paper or corrosion protection foil. It makes certain that the packed sections in the packing become secured against slipping.

 4. International air freight transmissions are to be packed accordingly in wooden boxes or in export packaging. Ensure that the maximum values of magnetic field strength are not exceeded, when sending by air-freight (IATA Dangerous Medium Prescript "Cap. 3.9.1.2. Magnetized Material"; ICAO Instructions "Packing Instruction 902").

On charge protection within the packing is required (this can be achieved by screw connections or keying). Corrosion protection with susceptible sections is to attach (oiled paper, protective plastic film, corrosion spray etc.).

 5. Seaworthy export supplies are to be packed in seaworthy export crates. The crates are made particularly and accurate to size, relating to orders by drawer operations. Crates are to be laid out with oiled paper corrosion resistant and seawater. Commodity is to be protected from corrosion additionally with spray or protective plastic film.

 6. It is to be made certain that the transmissions in the crate become secured against slipping (this can be by woods, wood slats and additional screw connections takes place). After the packing the sea-crates are to be

nailed correctly or bolted. The sea crates with safety tape become additional secured.

With the loading it is to be guaranteed that the transmissions become correctly and surely stowed away and secured. The transfer and loading correct of the transmission on means of transport are by the carrier on the waybill to certify on the load list, etc..

 7. Waste disposal: Observe the national waste disposal regulations.

Transport

- In order to avoid injury or damage to the unit it must be handled properly. In addition to following the instructions below, general health and safety good practice and specific accident prevention guidelines should be observed.
- For correct handling and storage comply with the following symbols:



Protect against moisture



Careful: glass



Up



Centre of gravity

- Do not compress the side walls of the unit or any attached parts by pulling obliquely on ropes or chains.
- Only remove handling safeguards once all installation work has been completed.
- When handling in a loading area make sure the unit cannot topple over or slip.
- Damage caused during transportation must always be reported to the manufacturer.

Storage

- If possible the unit should be stored in a closed room until final installation.
- If the unit is stored in the open it must be covered over with tarpaulins and open underneath, to allow condensation to drain off.
- If the unit has been packed for transportation by sea the packaging must not be damaged or opened during transit and storage.



Protect against moisture



Careful: glass



Up

Other related products

Automated Filtration



For fully automated cleaning 24/7 filtration we offer the Automag Skid.

High Pressure Filtration



For high pressure applications up to 1160 psi (80 bar), we offer the Micromag HP series.

Lifting & Handling



For safe and efficient handling of ferrous components see our range of lifting and handling products.

Premier Workholding

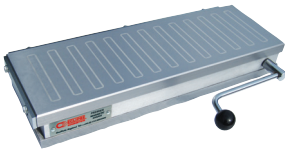

For the ultimate in precision accuracy see our range of workholding products.

www.eclipsemagnetics.com/na

For more information please contact our sales team

Eclipse Tools North America Inc.

442 Millen Road, Unit #9, Stoney Creek, ON L8E 6H2

T 1(800) 260-2124 F 1(800) 260-1410

E sales@eclipsetoolsinc.com W www.eclipsemagnetics.com/na

While every effort has been made to ensure the accuracy of the information in this publication please note that specifications may change without notice.

